

USER MANUAL

Before operating the device for the first time, carefully read this manual and ensure full understanding of all contents.



Precautions for Use

- During product operation, moisture may cause short circuits inside the device.
- Perform dehumidification treatment if the following conditions occur during use:
- The operating environment fails to meet requirements, i.e. ambient temperature outside the range of -10°C to 40°C, or humidity outside 10% to 90%.
- The screen has been left unused for more than 10 days.
- Damage caused by operation beyond specified environmental conditions shall not be covered by warranty.
- Even under qualified operating conditions, rapid inflow of hot and humid ambient air may lead to condensation on the device surface. Allow the device to dry completely before reuse.
- Condensation will occur if the product surface temperature is lower than ambient temperature, or when the cold product surface is exposed to hot and humid air.
- Condensation on the product surface may cause malfunction, which is non-warrantable.
- Do not direct air conditioner vents straight toward the screen.
- Direct airflow from air conditioner vents may result in screen condensation.
- If the air conditioner is placed too close to the screen, install an air deflector as illustrated to avoid airflow impact on the screen.

Contents

1. Scope of Application	4
2. Main Features.....	4
3. LED Module Appearance	5
4. Specifications	5
5. Mounting Holes.....	6
6. Cabinet Appearance	6
7. Installation Instructions	9
8. Preventive Measures	29
9. User Instructions.....	31

1. Scope of Application

The XIMGE-Series delivers high-quality content with outstanding clarity and intricate details for indoor environments. Featuring high flexibility in size and shape, the products can be customized to fit nearly any space, and installed in right-angle or tilted layouts to create unique and stunning visual installations. It provides a versatile, high-performance and durable solution for a wide range of indoor video display scenarios.

2. Main Features

1. 90° Right-angle Design

Presents delicate details and realistic image quality to realize seamless installation.

2. Magnetic Installation

Easy for quick mounting and disassembly.

3. Hard-wired Connection

Cableless internal structure with full hard connection for superior stability; supports full front-side maintenance and convenient after-sales repair.

4. Multiple Size Options

Die-cast aluminum cabinets with abundant specifications, enabling customized splicing as required.

5. Diversified Installation Methods

Supports hoisting, wall-mounted, floor-standing and other installation solutions.

6. Dual Redundancy

Dual backup design for signal and power supply (only available for 1000×500mm cabinets).

7. Independent Calibration

Modules are equipped with calibration functions to achieve independent brightness adjustment.

8. Cube Display Support

The 500×500mm cabinet allows four-side cutting, enabling perfect cube-shaped splicing and display.

3. LED Module Appearance



Front View – Rear View

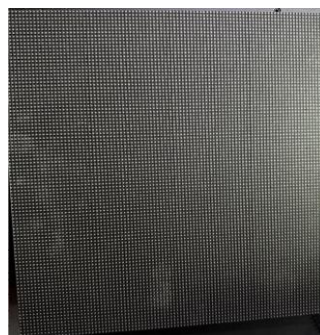

Front View – Rear View

4. Specifications

Category	Parameter	XIM019GE	XIM026GE	XIM029GE	XIM039GE
Model	Specification Code	XIM019GE	XIM026GE	XIM029GE	XIM039GE
Physical Parameters	Pixel Pitch	1.9 mm	2.6 mm	2.9 mm	3.9 mm
	Pixel Configuration	SMD1212	SMD1515	SMD2121	SMD2121
	Module Resolution (W×H)	128 × 128	96 × 96	84 × 84	64 × 64
	Module Dimension (W×H)	250 × 250 mm			
	Cabinet Resolution (W×H)	512 × 256	384 × 192	336 × 168	256 × 128
	Cabinet Dimension (W×H×D)	1,000×500×33.4 mm			
	Quantity of Modules per Cabinet	4 × 2			
	Cabinet Weight	10 kg			
	Cabinet Material	Die-cast Aluminum			
Optical Parameters	Brightness (Typical)	800 nits			
	Contrast Ratio	8,000 : 1			
	Viewing Angle (H × V)	160° × 140°			
	Gray Scale	≥14bit			
	Color Temperature	8,000±500K			
Electrical Parameters	Video Frame Rate	60 Hz			
	Maximum Power Consumption	500 (W/m ²)			
	Average Power Consumption	170 (W/m ²)			
	Power Supply	100~240 V AC (Standard 220V)			
	Refresh Rate	3,840 Hz			
Operational Parameters	Operating Temperature / Humidity	-10~40°C / 10~90% RH			
	Storage Temperature / Humidity	-20~40°C/ 10~65% RH			
	IP Rating	IP20			
Maintenance	Maintenance Access	Front Access			

* According to the current Hisense test environment

** Product specifications may vary per region, and specifications are subject to change. This material may include corporate names and trademarks of third parties which are the properties of the third parties respectively.

5. Mounting Holes

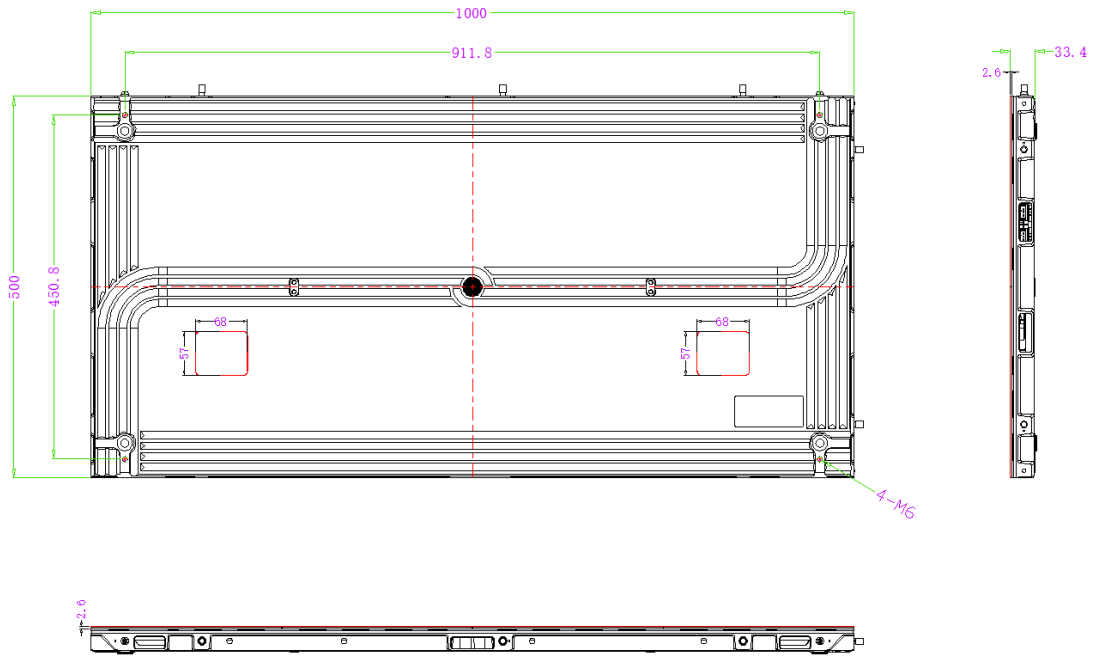

6. Cabinet Appearance



Rear

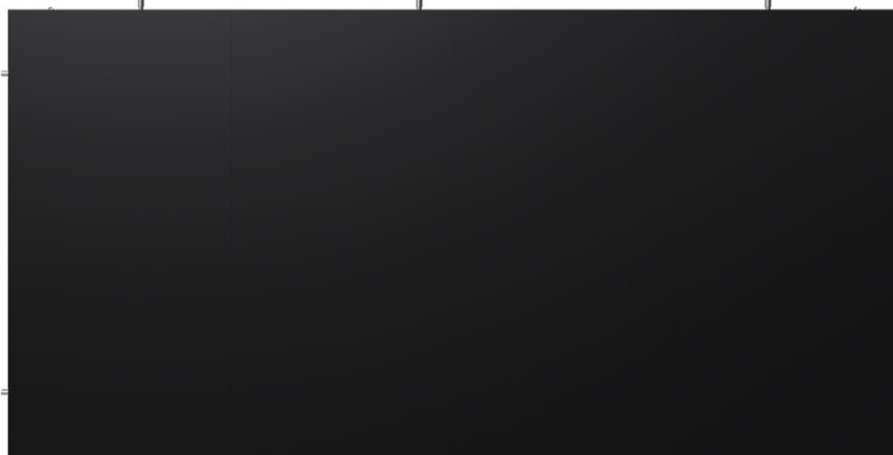

Front

LED Module Installation Method

The internal components of the display cabinet are shown in the figure below:

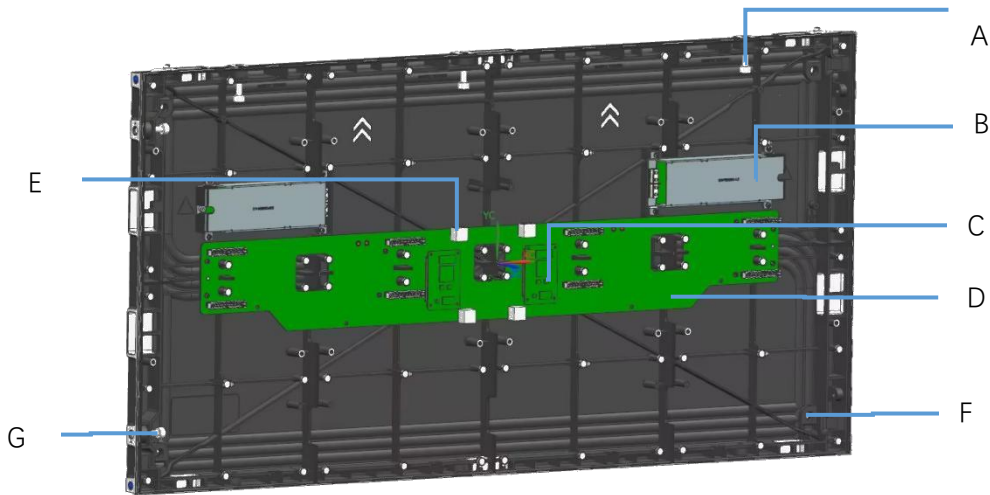

Schematic Diagram of LED Cabinet Internal Structure (1,000mm×500mm)

Marking	Name	Description
A	Vertical Mounting Screws	Used for fixing when splicing cabinets vertically.
B	Power Supply	Provides power for the cabinet. The additional power supply serves as a backup and is optional.
C	Receiving Card	Receives signals and controls parameters such as screen brightness and refresh rate. The additional receiving card acts as a backup and is optional.
D	HUB Board	Integrated adapter module for power supply and receiving card.
E	RJ45 Data Port	Output interface for data transmission between cabinets.
F	Front Mounting Screw Holes	Screw holes for fixing the cabinet during front installation.
G	Horizontal Mounting Screws	Used for fixing when splicing cabinets horizontally.

For detailed information about the LED module, please refer to the figure below.

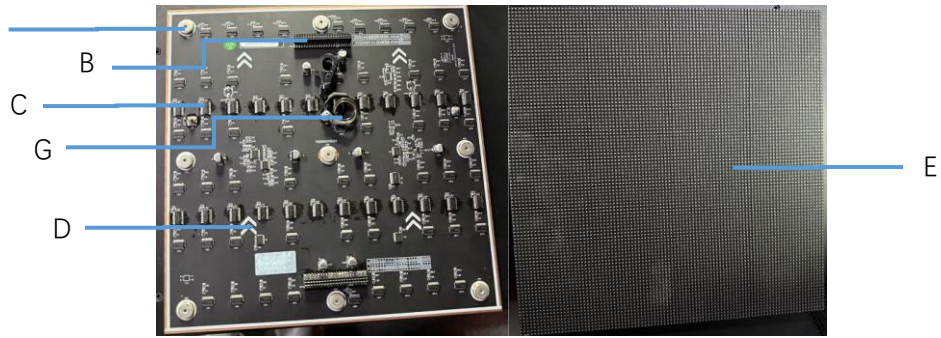

Rear/Front view of LED module

Label	Name	Description
A	Magnet	Secures the LED module to the cabinet.
B	Data & Power Interface	For data transmission and power input.
C	Driver IC	Core component of the PCB to drive the light-emitting chips.
D	Direction Arrow	Marks the mounting direction of the LED module.
E	Light-emitting Chip	The smallest display unit of the PCB panel.
G	Safety Rope	Hangs on the cabinet to fasten the LED module and prevent falling.

7. Installation Instructions

7.1 Installation Procedures

7.1.1 Construction and Installation of Structural Supports

Prior to the construction of the steel structure, all design drawings must be confirmed by our company or directly provided by us. Structural construction shall be carried out in strict accordance with the design drawings issued by our company.

As fine-pitch LED displays require high precision for mounting structures, the dimensional deviation of the finished structure shall be kept within an acceptable range, and no deformation shall occur on the overall structure.

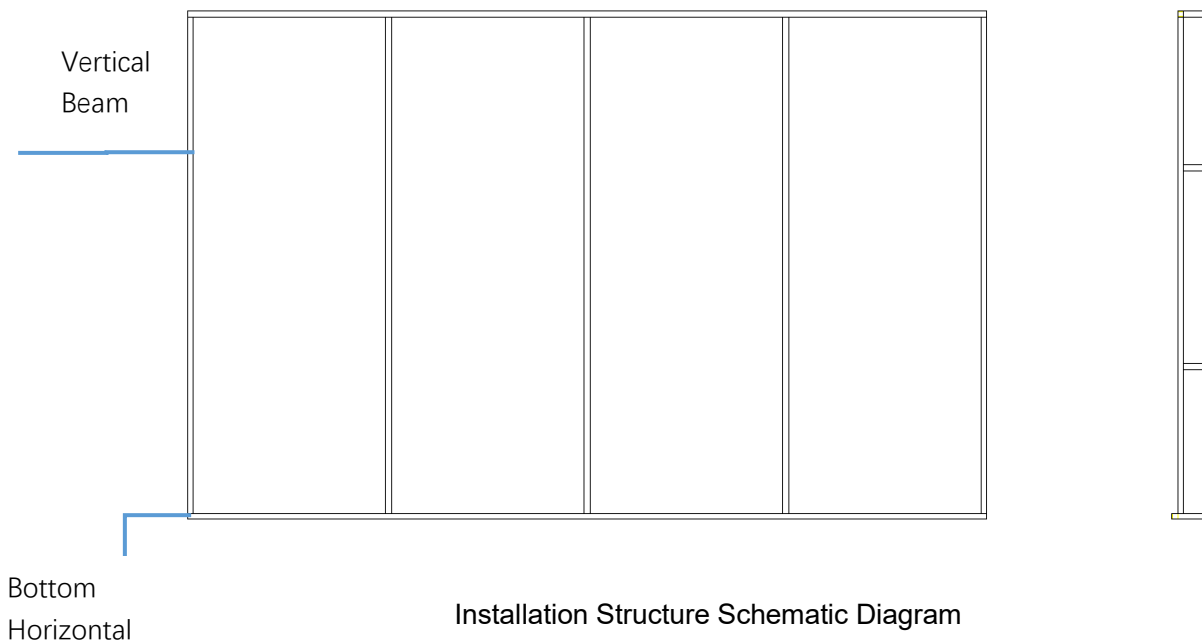

Installation Structure Schematic Diagram

(Refer to actual project drawings for details)

The overall structure shall be constructed on-site.

7.1.2 Cabinet Installation

- 1、 The flatness tolerance of the display surface of each cabinet component shall be controlled within ± 0.1 mm.
- 2、 For front-maintenance equipment, a minimum clearance of 100 mm shall be reserved between the cabinet perimeter and walls to ensure effective heat dissipation and ventilation.

Notice

To guarantee the flatness of the installation layers, start installation from the bottom center and proceed toward both sides in sequence. After completing the first layer, install the second layer following the same center-to-side order, and apply this procedure to all subsequent layers.

Note that all direction arrows on the cabinets must point upward.

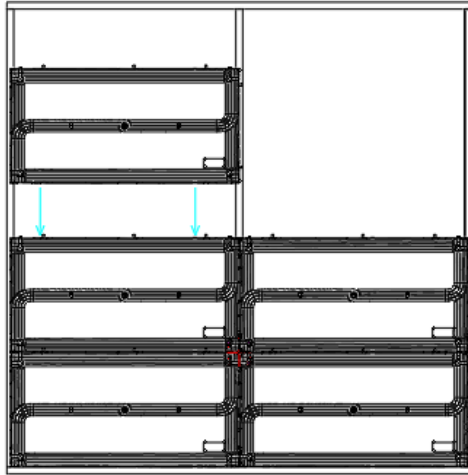

01 Side Installation Schematic of Coupling Plates Inside Cabinet

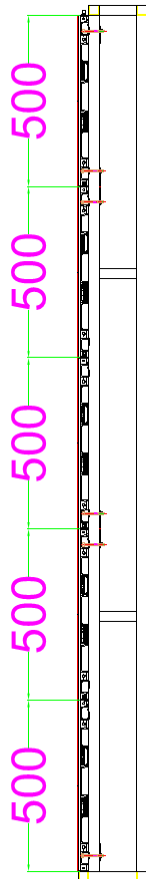

02 Schematic Diagram of Cabinet Connection Pieces

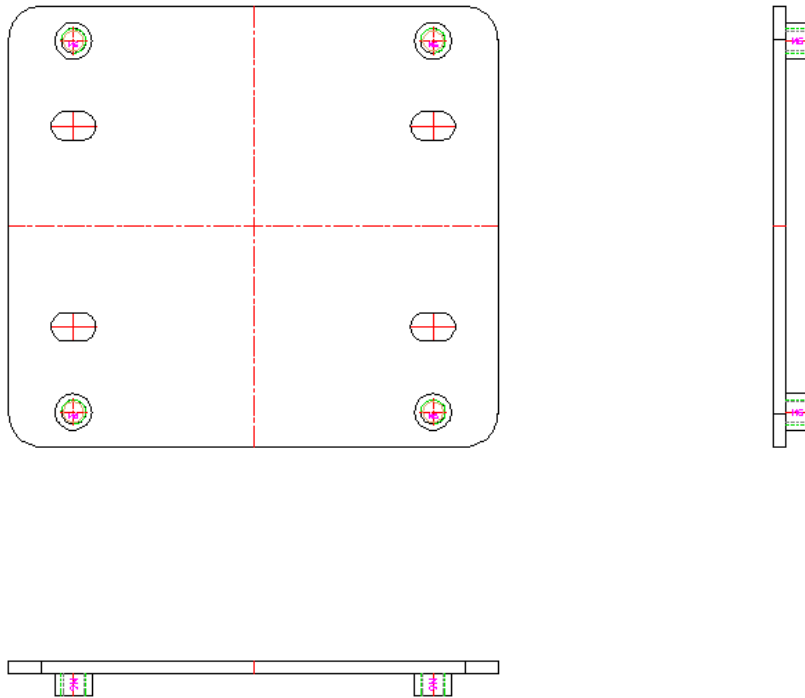

Schematic of Coupling Plates for Fixing Screen Frame

The installation sequence is as follows: First, fasten the upper and lower screws on the left and right sides of the cabinets. Second, secure the connecting parts inside the cabinets. Finally, install the rear connectors to firmly fix the cabinets onto the steel structure.

Note: The flatness error of the bottom cabinets on the first layer must be controlled within 0.05 mm. Otherwise, flared gaps will appear at the top or bottom seams of the cabinets, resulting in installation failure of the upper cabinets.

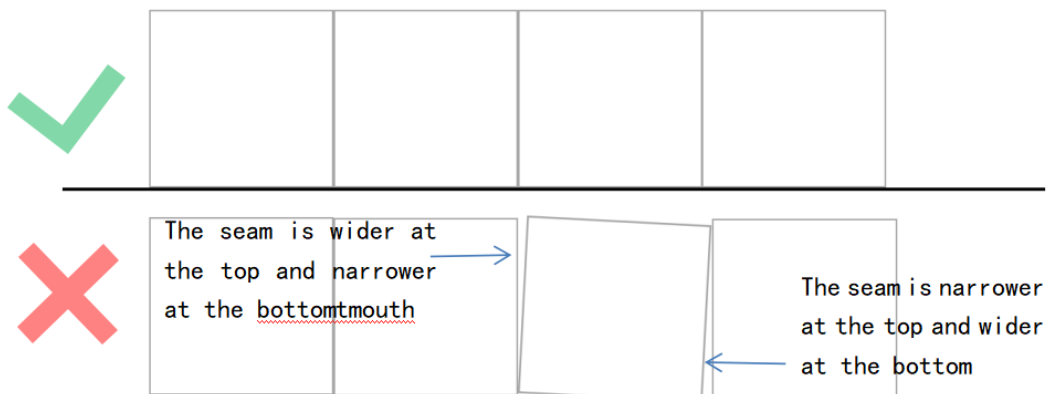

If the top of the joint is wider while the bottom is narrower, the overall installation gap will be excessive when mounting the top row of cabinets, resulting in obvious visible dark lines.

If the top of the joint is narrower while the bottom is wider, the installation space will be compressed for the top 2–3 rows of cabinets, which may cause problems such as failure to place cabinets properly or inability to disassemble and assemble LED modules.

Notes

- 1、 During steel structure construction, the flatness of the bottom bearing beams must be strictly guaranteed.
- 2、 When installing cabinets, ensure the installation flatness of the bottom cabinet row.

7.1.3 Connection of Signal Cables and Power Cables

Signal & Power Cable Installation

Description

Power interfaces are arranged inside the cabinet. Sufficient space shall be reserved for cable routing. The cable specification is $3 \times 1.5 \text{ mm}^2$, supporting a maximum of 8 cabinets (AC 220V).

The main interfaces of the cabinet adopt hard connection. This manual specifies the hard connection method, with detailed operating instructions as follows.

Each single data port is equipped with two types of AC power cabinet data cables to realize AC power supply and data transmission during connection.

Internal Power Wiring of Cabinet

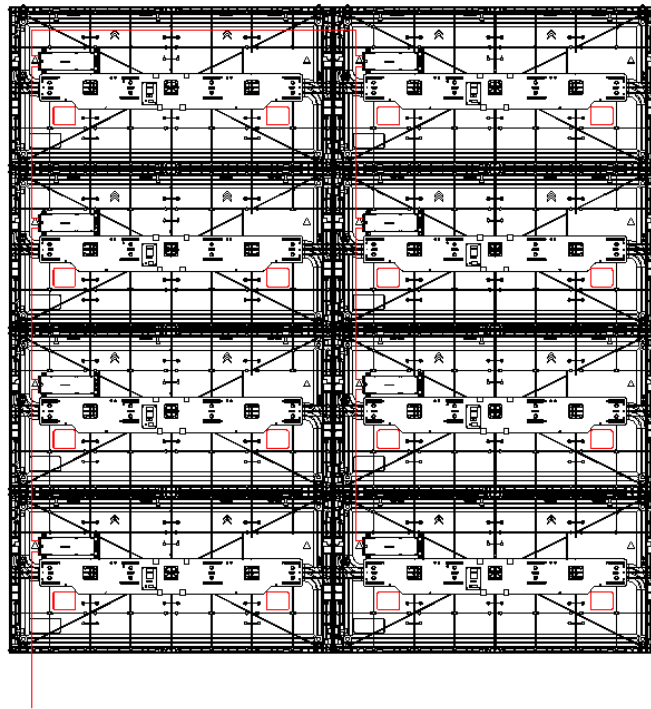

Power

(The above figure may differ from the actual product and is for wiring reference only.)

Note: The maximum load of one power cable: no more than 8 cabinets (AC 220V).

The internal network cables of the cabinet are pre-connected.

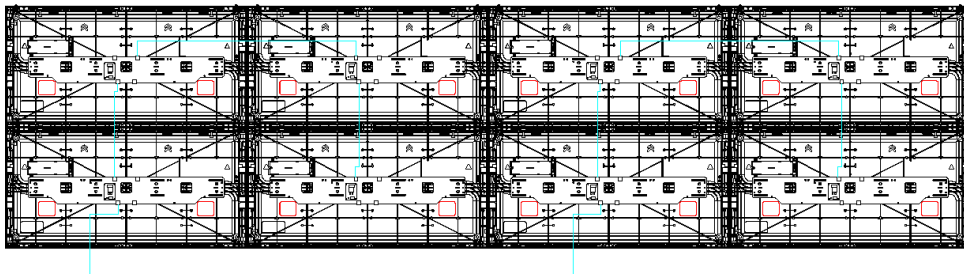

Signal in

Signal in

(The above figure may differ from the actual product and is for wiring reference only.)

Two network ports on the HUB board are non-directional, allowing connection from top to bottom or bottom to top.

① Cabinet Arrangement Sequence

4-1	4-2	4-3	4-4
3-1	3-2	3-3	3-4
2-1	2-2	2-3	2-4
1-1	1-2	1-3	1-4

The first cabinet is located at the bottom-left corner of the screen, with the remaining cabinets arranged upward on the right side.

① LED Module Arrangement

Cabinet dimension: 1000 × 500 mm; LED module dimension: 250 × 250 mm.

Each cabinet contains 8 LED modules, arranged in 4 columns and 2 rows.

① Layout of Internal Connectors in the Cabinet

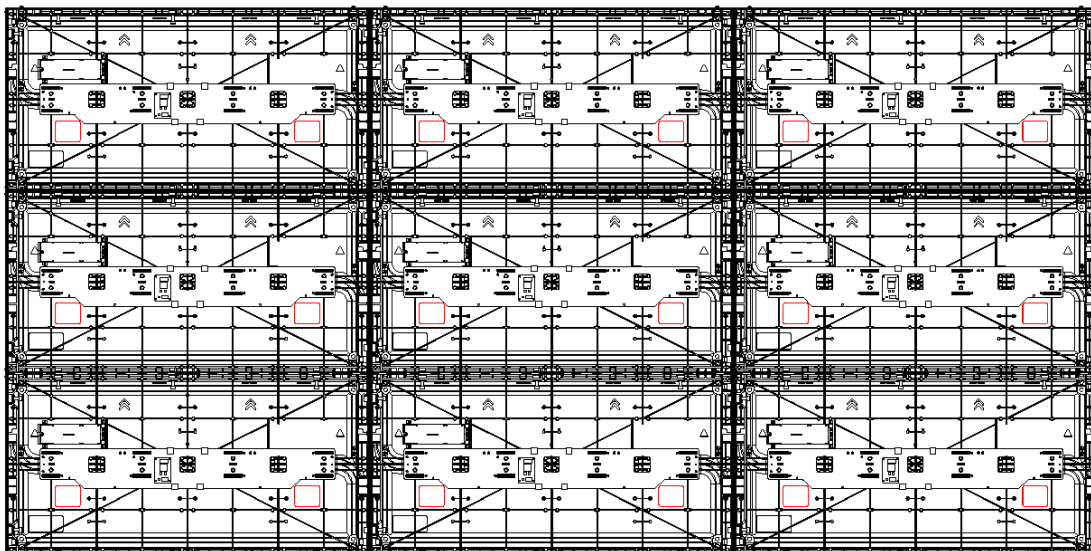

This panel is made of die-cast aluminum. Mounting through holes are provided at four corners, enabling both wall-mounted installation and fixed mounting with steel structure connecting brackets.

② Layout Scheme of Cabinet Back Pressure Plate

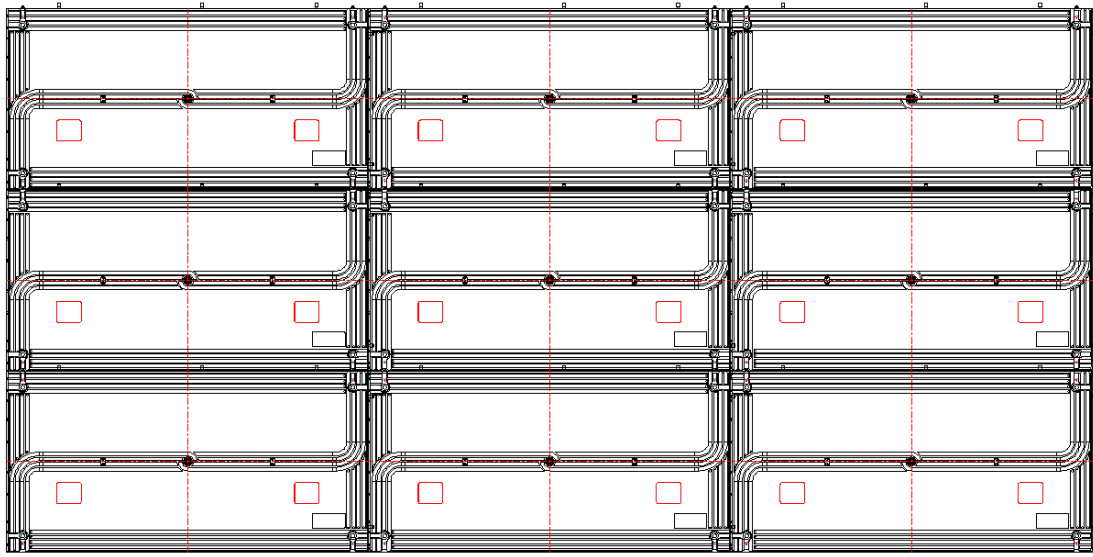

7.1.4 Panel Installation

Description

- 1、 The outer cabinet and LED modules shall be installed separately. LED modules can only be installed after the outer cabinet is fully mounted and all cable connections are completed.
- 2、 The mounting direction of LED modules must be consistent with the arrows marked on the panel and outer cabinet.
- 3、 Before installation, check for attachments on the magnets to prevent uneven assembly.

Notes

If the LED module surface is uneven during installation, first remove the module with a maintenance vacuum suction cup, level it with special tools, then reinstall it onto the cabinet.

7.2 Bottom Cabinet Installation

First, align and fix the bottom cabinets in left-to-right order. After confirming horizontal alignment between adjacent cabinets, fasten two M6 screws on the left and right sides for secure locking.

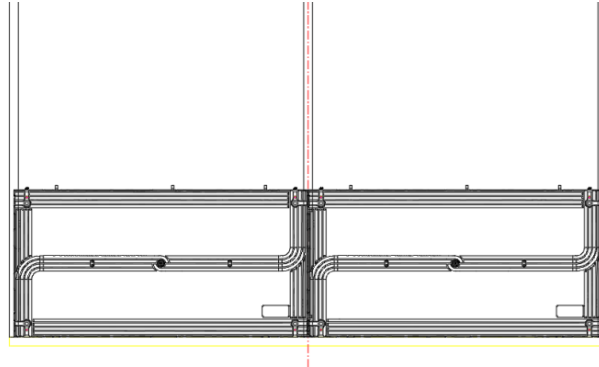

7.3 Upper Cabinet Installation

Install the cabinets one by one in left-to-right order. After all cabinets are evenly aligned, position the upper cabinets onto the bottom cabinets via positioning pins. Similarly, confirm the alignment, then fasten the two factory-equipped M6 screws on the top of the cabinets to secure adjacent cabinets on the same horizontal plane.

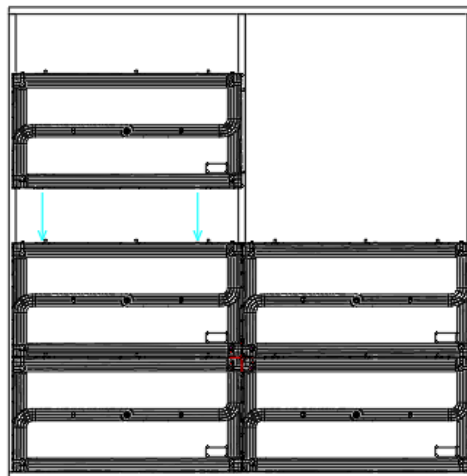

7.4 Front Connector Installation

Mount the Coupling Plate with four M6×52 screws, and fasten the main Coupling Plate firmly to the steel frame.

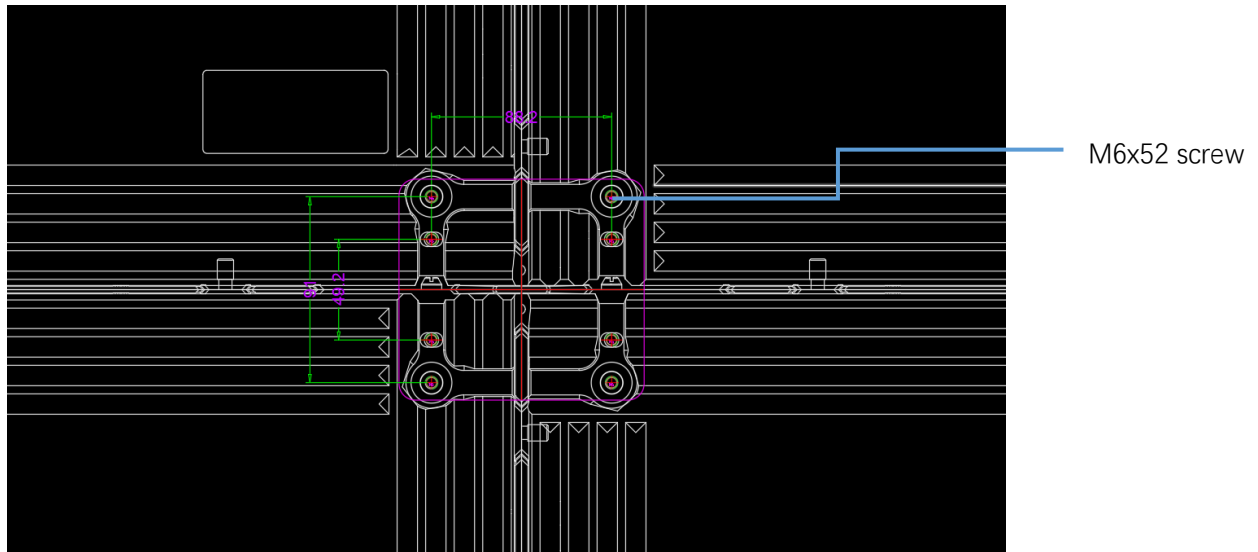

Schematic Diagram of Front Installation Details

7.5 Screen Wiring and LED Module Installation

All signal cables and power cables inside the screen enclosure enter through reserved openings on the bottom cabinet by default.

Power transmission can be realized by connecting the connectors of internal cabinet wiring with each other.

The LED modules shall be installed in a standardized sequence: install from the far left to the right in order, then arrange gradually upward from the bottom row. To ensure accurate matching, the serial numbers of LED modules must be completely consistent with those of the corresponding cabinets.

7.6 Direct Wall-mounted Installation (Wooden Wall & Concrete Wall)

Pre-installation Preparation

- Inspect the on-site wall to confirm construction conditions and compliance of wall materials.
- Use a laser level to check the mounting surface and wall flatness.

Step 1

Take out the cabinet, and remove the LED modules from the cabinet with a vacuum suction tool. If modules are not pre-installed on delivered cabinets, skip this step and proceed directly to installation.

Step 2

Fix the cabinet to the wall with electric drill and fasteners: self-tapping screws for wooden

walls, expansion screws for concrete walls. Fasten screws at four corner mounting holes in sequence to complete single cabinet installation.

It is recommended to install the bottom row of cabinets first, then lock the left and right connecting screws between adjacent cabinets.

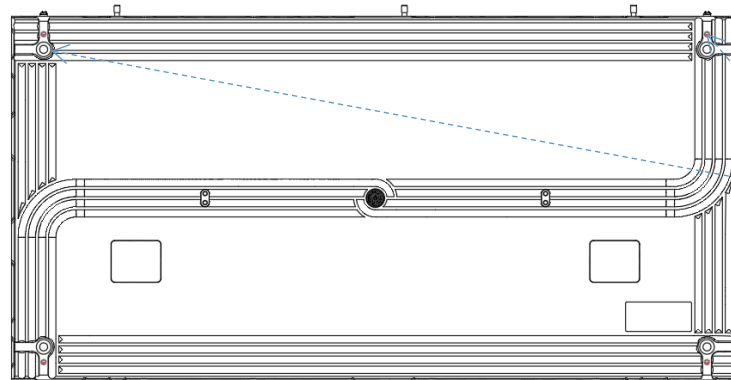

Fasten this position with self-tapping screws or expansion screws through the mounting holes.

Wooden Wall Installation

Step 3

After installing the bottom row of cabinets, mount the upper rows in sequence. Fasten the upper and lower connecting screws as well as the left and right connecting screws between cabinets until the entire screen assembly is fully installed.

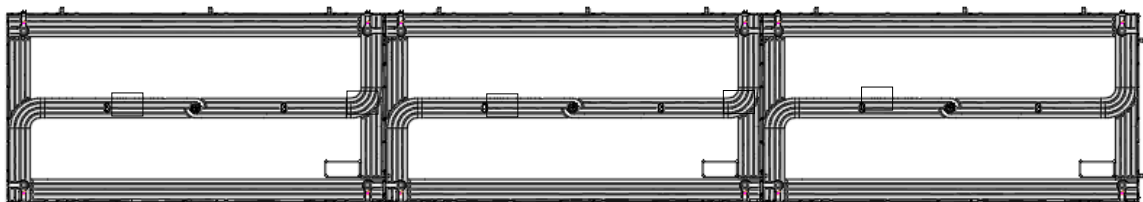
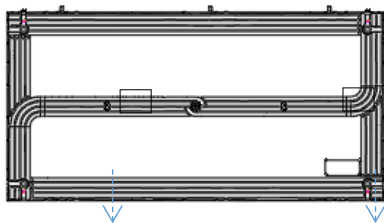

Fasten the upper-lower and left-right connecting screws.

Step 4

Route and connect all cables in accordance with the official connection diagrams to ensure full consistency with the drawings.

After all wiring is completed:

- 220V power supply supports up to 8 cabinets;
- 110V power supply supports up to 4 cabinets;
- Red cables: power cables;

- Cyan cables: signal cables.

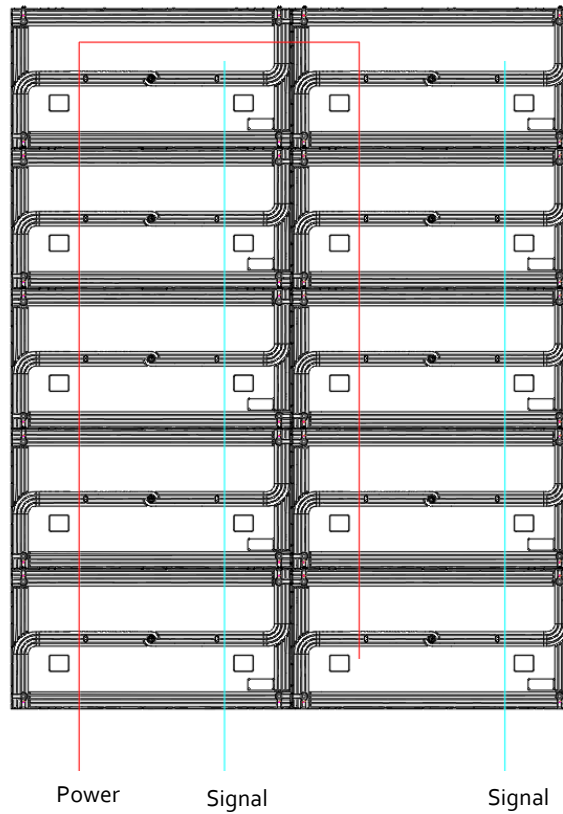

Step 5

Power on and check whether all cabinets are powered on normally, whether the receiving cards receive signals, and whether the indicator lights flash correctly.

Step 6

Install the modules. First, hang the module safety ropes on the corresponding mounting positions of the cabinets, then reinstall the modules in order. Ensure the display surface is flat without front-to-back misalignment.

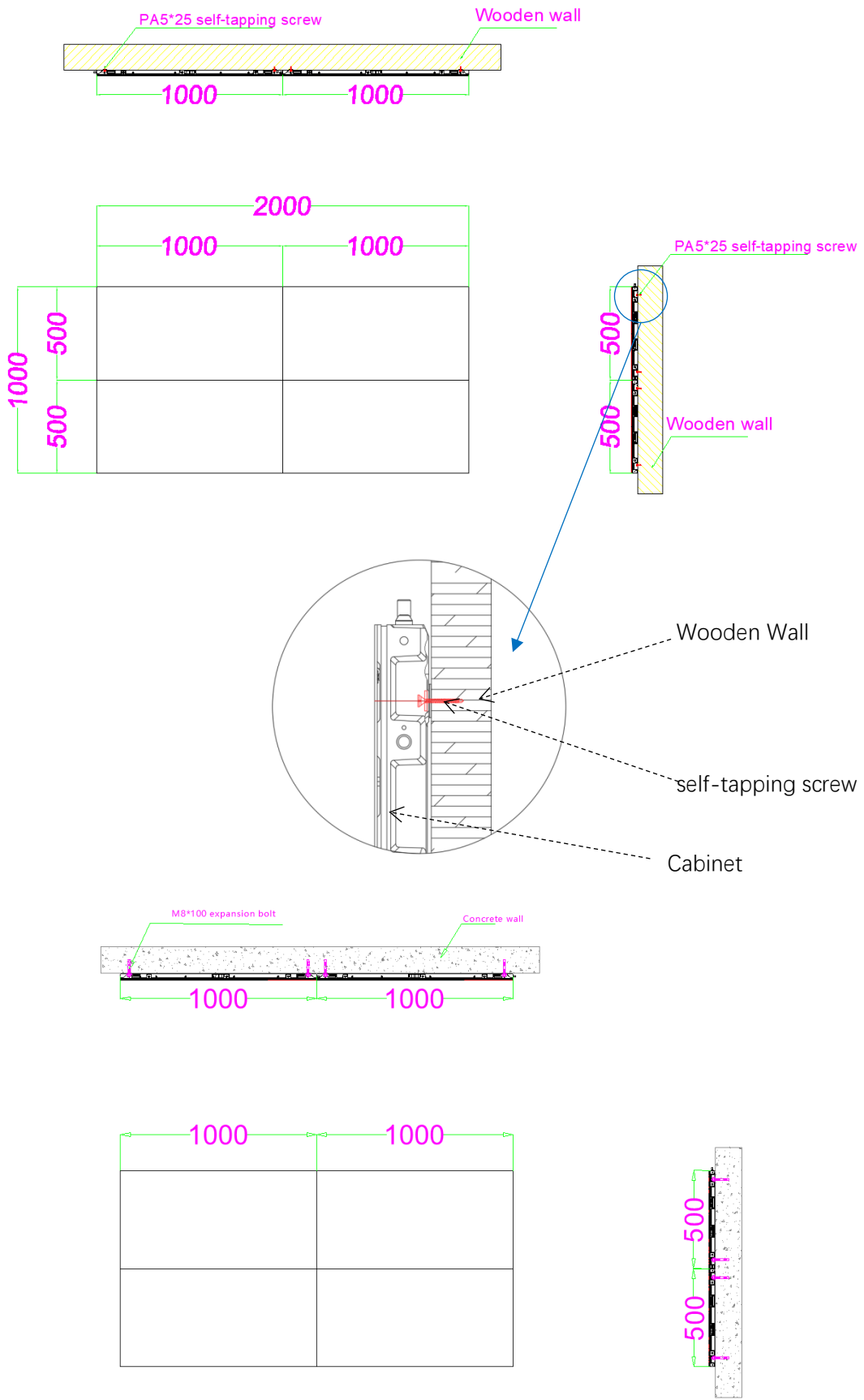

7.7 Wall Bracket Installation

Pre-installation Preparation

1. Inspect the on-site wall to verify construction conditions and material compliance. Use a laser level to check the flatness of the concrete mounting surface.
2. For screens composed of multiple cabinets, remove all modules in advance to facilitate internal wiring and assembly. After all cabinets are installed, connect the cables in accordance with the official wiring diagrams, then mount the LED modules. If modules are not pre-installed on delivered cabinets, direct installation is available.

Step 1

Adjust the hook beams to align with the cabinet mounting holes, then secure them with M6×20 screws.

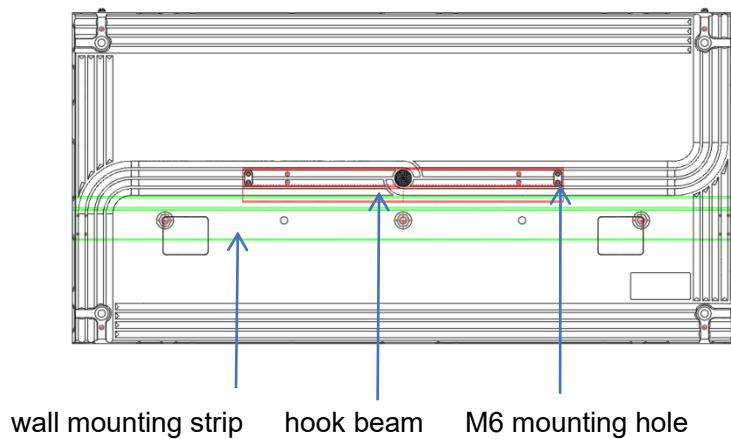

Step 2

Drill holes at corresponding horizontal positions on the wall, and fix the wall mounting strips with M8×100 expansion bolts.

Step 3

Place the assembled cabinets together with hook beams onto the wall mounting strips to complete installation. Check for stable mounting afterward.

Step 4

Install the remaining cabinets in sequence following the above steps. Fasten the upper-lower and left-right connecting screws between cabinets during installation, and inspect overall stability upon completion.

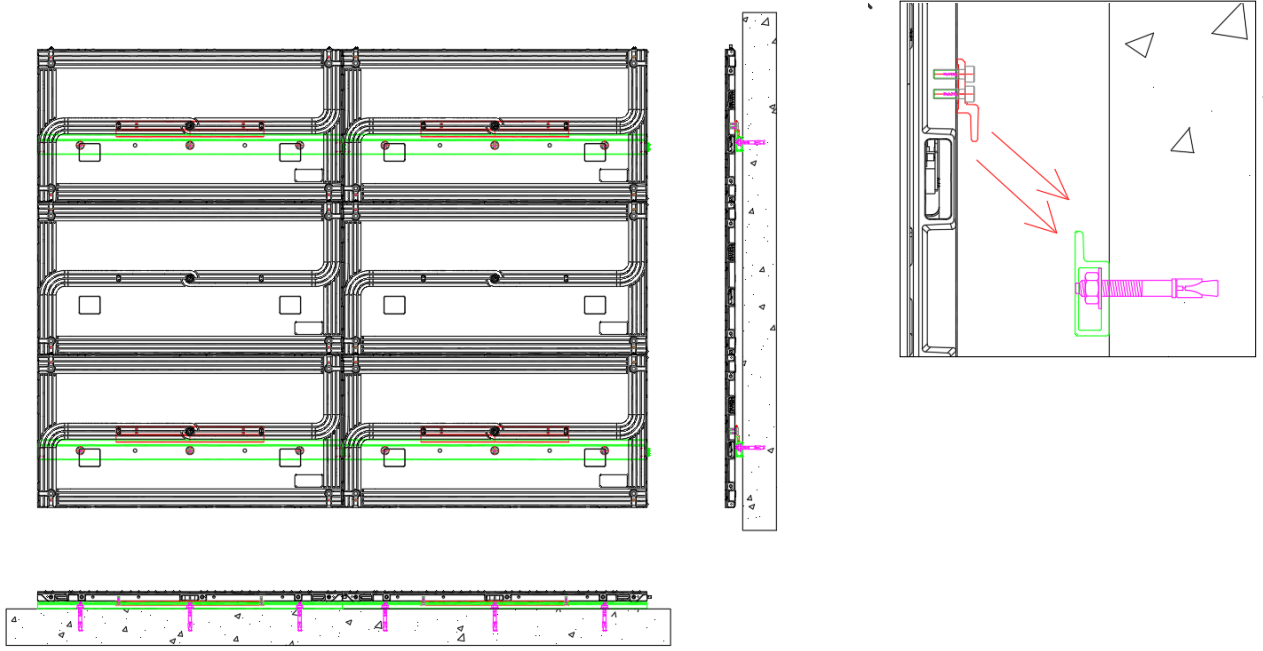

Wall Mounting Strip Installation Schematic

Step 5

Connect all cables strictly in accordance with the company-provided wiring diagrams to ensure full compliance with the drawings. After completing all wiring, install the LED modules on the cabinets.

(Up to 8 cabinets under 220V power supply; up to 4 cabinets under 110V power supply. Red cables indicate power lines, and cyan cables indicate signal lines.)

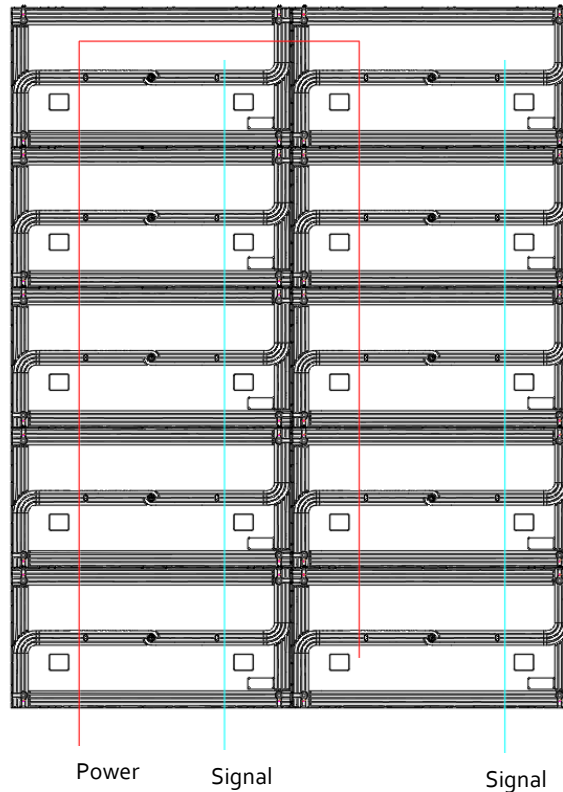

Step 6

After power-on, check that all cabinets are powered normally, the receiving cards have stable signal, indicator lights flash correctly, and all display cabinets are aligned flush.

Step 7

Install the modules. First hang the module safety ropes to the corresponding mounting points on the cabinets, then reinstall the modules in order. Ensure the entire display surface is flat with no front or rear misalignment.

7.8 Hanging Installation

Note: The hoisting method supports a maximum height of 20 cabinets.

Pre-installation Preparation

1. Check whether the site meets hoisting construction requirements, and confirm that lifting points, lifting ropes and other components comply with installation standards.
2. For large-scale spliced screens with multiple cabinets, remove all modules in advance to facilitate cabinet wiring and connection assembly. After all cabinets are installed, connect the cables per the official wiring diagrams, then install the screen modules. If modules are not pre-assembled on delivered cabinets, this step can be skipped for

direct installation.

Step 1

Match and mount the lifting beams to the corresponding cabinet mounting holes, and adjust the flatness of the beam surface. Fix and install the first cabinet first.

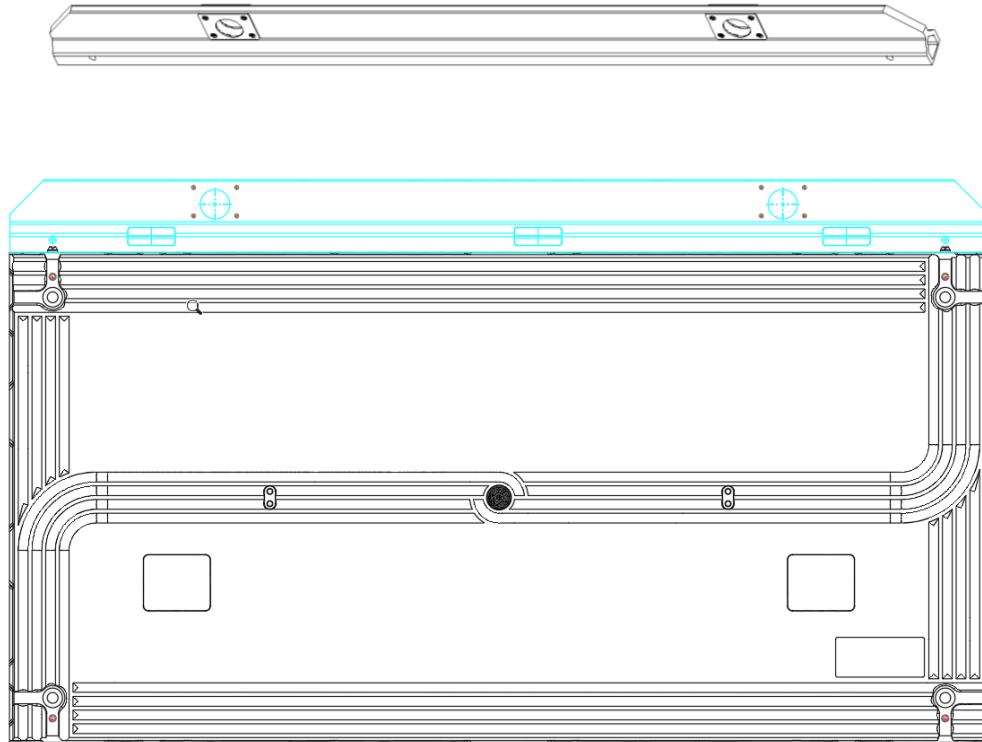

Schematic Diagram of Single Cabinet and Lifting Beam Installation

Step 2

Install the second lifting beam and cabinet in the same manner, then fasten the left and right connecting screws between adjacent cabinets.

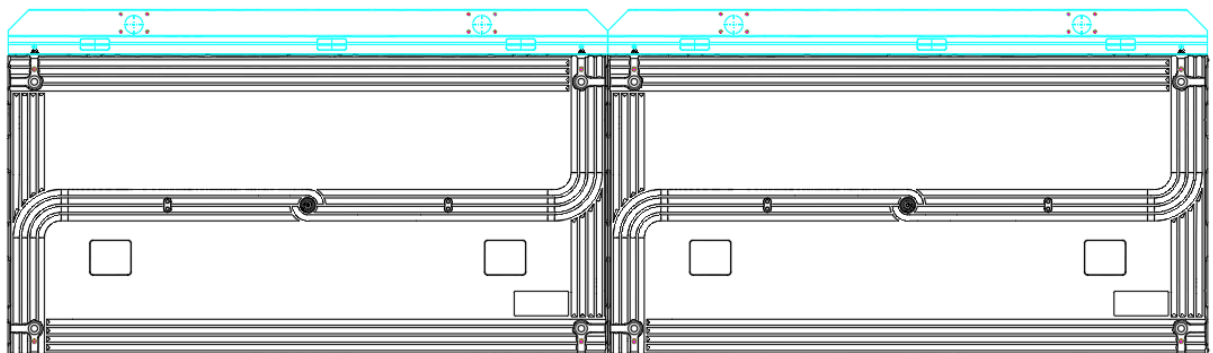

Schematic Diagram of Multiple Cabinets and Lifting Beam Installation

Step 3

Install the remaining cabinets in the same way. Fasten the left-right and upper-lower connecting screws between cabinets, install the corresponding Coupling Plates, and adjust the overall flatness.

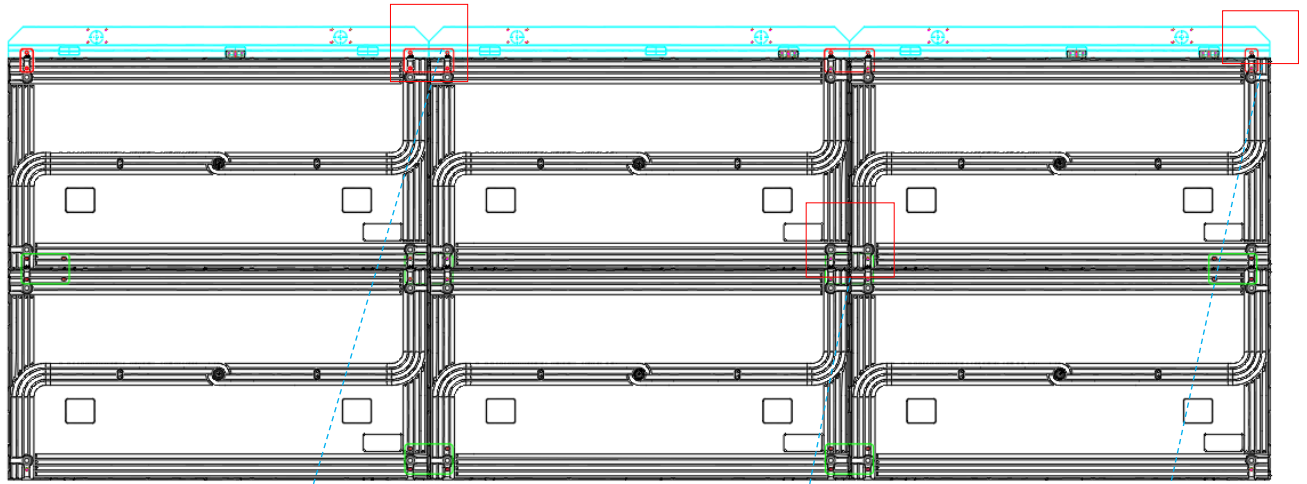

Hanging Rear View

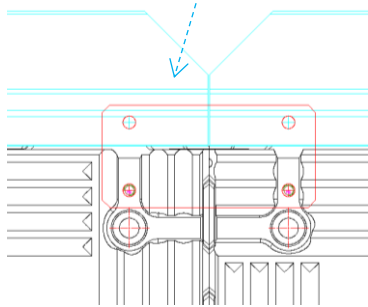

Hanging Beam & Cabinet Coupling Plate

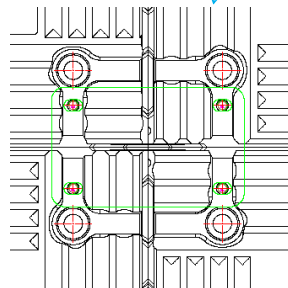

Cabinet-to-Cabinet Coupling Plate

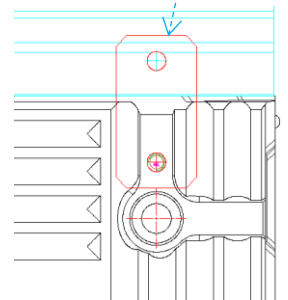

Side Hanging Beam and Cabinet Coupling Plate

Step 4

Connect power cables and network cables in accordance with the drawings provided by our company. Power on and inspect all cabinets for normal power supply, stable signal reception of receiving cards, and normal flashing of indicator lights.

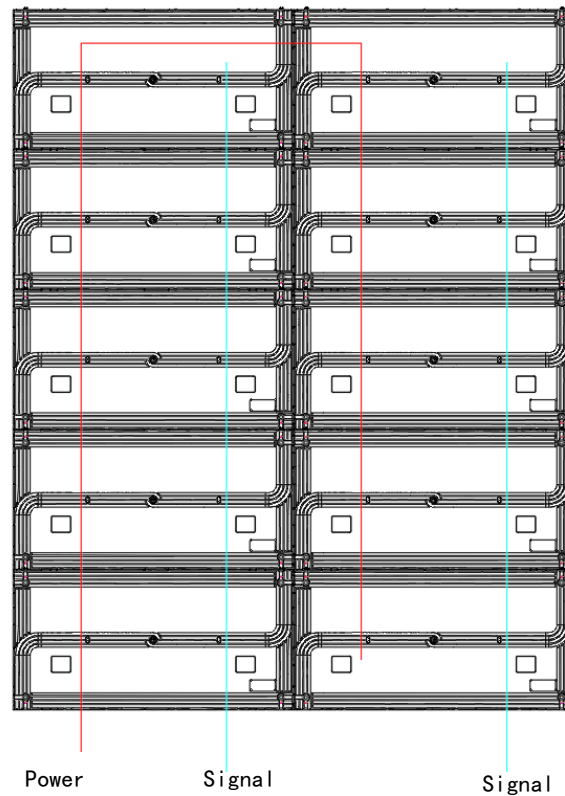

(Max. 8 cabinets for 220V power supply; max. 4 cabinets for 110V power supply. Red wires are power cables, and cyan wires are signal cables.)





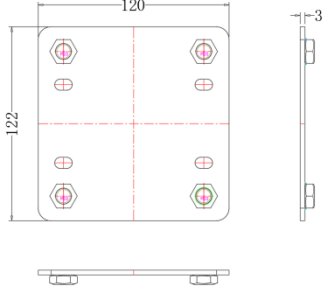
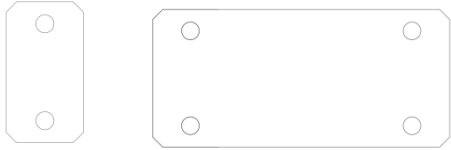

Step 5

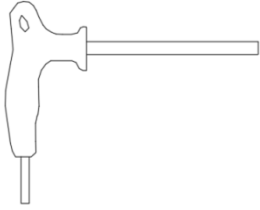
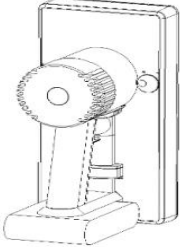
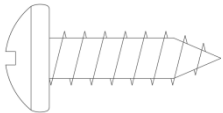
Install the modules. First attach the module safety ropes to the corresponding mounting positions on the cabinets, then reinstall the modules in sequence. Ensure the display surface is fully flat without any front-to-back misalignment.

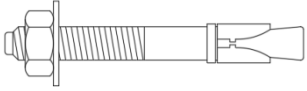
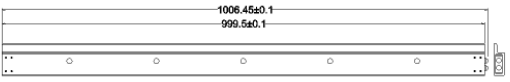
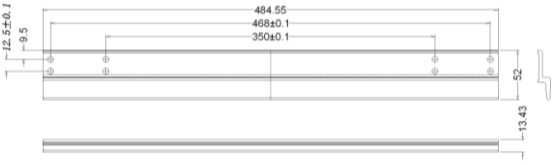
7.9 Pre-installation Materials Preparation

<p>Coupling Plate(For cabinet front maintenance assembly)</p>	
<p>Suspension Bracket (For fixing cabinets and lifting beams)</p>	
<p>Coupling Plate Screw (M6x55)(For fixing lifting beams and Coupling Plates)</p>	
<p>Front Maintenance Coupling Plate Screw (M6x16)(For fixing cabinets and Coupling Plates)</p>	
<p>Coupling Plate Fastening Tool(M6, M8 hex socket wrenches)</p>	
<p>Vacuum Suction Tool (Special for P1.9, P2.6, P3.9, P4.8 models)</p>	
<p>PA5x25 Self-tapping Screw(For wooden wall installation)</p>	

<p>M8×100 Expansion Bolt(For concrete wall installation)</p>	
<p>1m Wall Mounting Beam(For wall-mounted installation) (Optional)</p>	
<p>Wall Hook Beam(For wall-mounted installation) (Optional)</p>	
<p>1m Hanging Beam(For hoisting installation) (Optional)</p>	
<p>Hex Socket Wrench</p>	
<p>Laser Level</p>	

8. Preventive Measures

Temperature Range

- Operating ambient temperature: -20°C ~ 40°C
- Storage temperature: -20°C ~ 50°C

Humidity Range

- Operating humidity: 10%–90% RH (relative humidity), no condensation allowed.
- Storage humidity: 10%–65% RH (relative humidity), no condensation allowed.

Dustproof & Waterproof

- The cabinet protection rating is IP20. Infiltration of moisture from the side or rear may cause electrical short circuits, resulting in damage to circuit boards and electronic components.

ESD Protection

- The power supply, cabinet and metal shell of the screen body must be reliably grounded with a grounding resistance below 10Ω, to prevent electrostatic discharge that may damage electronic parts.

Maintenance Instructions

- There are potential electrical hazards inside the cabinet. Non-professional personnel are prohibited from opening it without authorization.

Environment Selection

- Operate in a dust-free and low-humidity environment to avoid secondary pollution during cleaning.

Dust Prevention & Cleaning

1. Regular cleaning: Remove dust and dirt on the display regularly with brushes and vacuum cleaners. Do not wipe directly with a damp cloth.
2. Connection inspection: Periodically check the tightness of network cable connections and reinforce loose parts in a timely manner. Inspect power voltage and control card contact status regularly.
3. Ventilation & drying: Keep indoor ventilation and a tidy environment to extend service life and reduce failure rates.
4. Usage cycle: It is recommended to let the LED display rest for more than 2 hours daily. Power on the screen at least once a month for continuous operation over 2 hours. In high-humidity environments, if the screen is unused for more than 3 consecutive days, perform preheating lighting to eliminate internal moisture.
5. Virus prevention: Regularly update computer antivirus software and playback software to ensure system security.
6. Periodic inspection: Monitor the operating status of the display, keep wiring intact, and repair or replace damaged components promptly when necessary.

- Follow the above specifications during daily operation and maintenance to ensure stable performance and longer service life.
- The recommended cleaning cycle is 1–2 months. For dusty areas, shorten the cycle to half a month.

Mechanical Damage & Chemical Corrosion Prevention

Avoid heavy extrusion and external force impact on the display. Do not install the screen in vulnerable areas. Prevent water and chemical liquid from entering the cabinet, especially contact with the metal shell.

9. Dehumidification & Gradual Power-on Procedure

Electrostatic Discharge (ESD) Protection

Installers must wear anti-static wristbands and gloves, and all tools must be strictly grounded during the assembly process.

Operating Methods

It is strictly prohibited to assemble modules, cabinets or the entire screen while the power is on.

All operations must be performed with the power completely turned off to ensure personnel safety.

Disassembly and Transportation

Do not drop, push, squeeze or compress the packaging, so as to prevent LED modules from falling or colliding, and avoid problems such as kit damage, LED module damage, scratches and fractures, and component detachment.

Environmental Safety Inspection

A thermometer and a hygrometer must be installed on the display screen to monitor the environmental conditions around the screen body, so as to detect humidity, moisture and other related problems in a timely manner.

Use of the Display Screen

A. The environmental humidity must be strictly controlled to maintain it within the range of 35% Relative Humidity (RH) to 55% RH (*For optimal performance and longevity, maintain humidity between 35% and 55% RH*) . It is recommended to turn on the display screen at least once a week, and each operation should last more than four hours.

B. When the environmental humidity exceeds 55% Relative Humidity (RH), dehumidification measures must be taken. To reduce the impact of moisture on the screen and the risk of operational failures, it is recommended to use the screen for at least eight hours a week under normal working conditions.

C. If the display screen is in a dormant state for a long time, preheating and dehumidification must be performed before reactivation to avoid problems caused by Moist LED lamps. The recommended operation process is as follows: first set the screen brightness to 0% and keep it for two hours, then gradually increase the brightness to 10%, 20%, 40% and 60% every two hours. This gradual brightness adjustment is used to simulate the aging process. Strictly following this process is crucial to ensuring the best performance of the display screen and maintaining warranty rights and interests.